

UNIQ



UM-300, UM-301 CCD Camera User's Manual

Table of Contents

Warning	1
Precautions	1
Limited Warranty	1
1. Introduction	2
1.1 General Description	2
1.2 Features	2
1.3 Applications	2
1.4 CCD Imager Spectral Response Curve	2
1.5 Camera Specifications	3
1.6 Camera Dimension	3
2. Camera Setup	4
2.1 Basic Camera Setup	4
2.2 Camera and Frame Grabber System Setups	4
3. Camera Functions	5
3.1 12-Pin Connector	5
3.2 Shutter Speed Dial Switch	5
3.3 Normal and Asynchronous Capture Mode (NRM/ASM)	5
3.4 Gain Control Mode	6
3.5 Gamma 1.0 and 0.45 Mode	6
3.6 Field and Frame Mode (FLD/FRM)	7
4. Timing Signals	8
4.1 Asynchronous Capture	8
4.2 Pulse Width Shutter Control	8
4.3 External Synchronization and Gen-lock	9
4.4 Asynchronous Capture at Field Mode (Shutter at 0)	9
4.5 Asynchronous Capture at Frame Mode (Shutter at 0)	9
4.6 Integration	10
4.7 Strobe	10
5. Camera Malfunction	11
6. Technical Support Information	11

WARNING

**TO PREVENT FIRE OR ELECTRIC SHOCK HAZARD,
DO NOT EXPOSE THIS CAMERA UNIT TO RAIN OR MOISTURE.
DO NOT ATTEMPT TO REMOVE CAMERA COVER OR MODIFY THE CAMERA UNIT,
WARRANTY WILL BE VOIDED.**

PRECAUTIONS

**Do not attempt to disassemble, modify, or repair the camera. Contact UNIQ for help.
Do not point the camera at bright objects, such as the sun, for a long period. It may cause CCD blooming and permanent damages.
Do not operate the camera beyond the temperature range. Avoid using the camera above 90% humidity.
Do not use unregulated power supply source.
Do not touch CCD glass cover with fingers or any hard objects other than professional glass cleaning solvents.**

Limited Warranty

UNIQ warrants to the original customer to be free from defects in material and workmanship for two full years from the date of original purchase. This warranty covers failures or damages due to defects in material or workmanship, which occur during normal use. It does not cover damages or failures, which result from shipment, mishandling, abuse, misuse, or modification.

A Return Material Authorization (RMA) number is required prior to returning any UNIQ product for repair or replacement.

This proprietary document may not be reproduced or photocopied without the consent of UNIQ. UNIQ makes no warranty or assumes no responsibility for any errors, which may appear in this document. UNIQ reserves the right to make changes without notice or obligation.

For immediate technical assistance, please call (408) 330-0818 or email to tech@uniqvision.com

1. Introduction

1.1 General Description

UM-300/UM-301 series is a near infrared (NIR) CCD camera. This camera is four times more sensitive than the conventional CCD camera at 945 nm wavelength. Smear is significantly reduced and dynamic range is much greater than the current CCD cameras. Asynchronous reset allows the image to be captured at very high shutter speed without smearing. The rotary switch located on the rear plate can easily change various shutter speeds for asynchronous reset applications. The asynchronous reset input pinout is located on 12-pin connector. AGC/MGC, Gamma 1.0/0.45, and Frame/Field mode selections are also available on the rear plate.

1.2 Features

- 1/2" **EXview HAD CCD**^{*} Imager
- High sensitivity @ 945 nm
768 x 494 (EIA); 752 x 582 (CCIR)
- Asynchronous capture
- Shutter Speed (1/60-1/31,000)
- 56 dB (AGC Off)
- Compact Size and lightweight
- AGC/MGC selectable
- Gamma 1.0/0.45 selectable
- Frame/Field mode selectable
- Long-term frame integration

1.3 Applications

UM-300/UM-301 applications include night surveillance, car-mounted, and others where near infrared and high sensitivity is required.

1.4 CCD Imager Spectral Response Curve

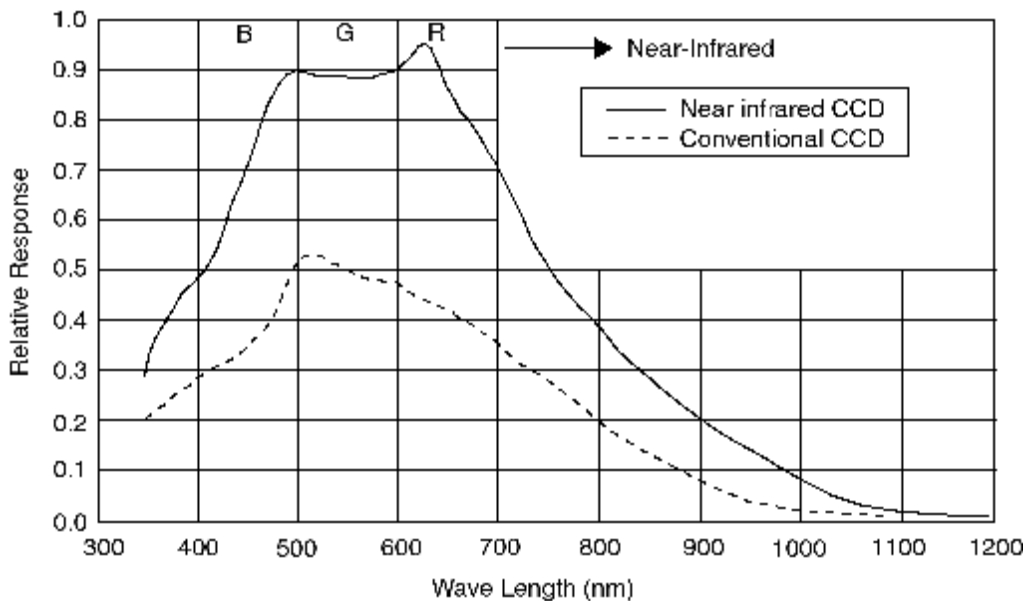

^{*} EXview HAD CCD is a registered trademark of Sony Corporation.

1.5 Camera Specifications

Model	UM-300 (EIA)	UM-301 (CCIR)
CCD Sensor	1/2" Interline-Transfer EXview HAD CCD	
Chip Size	6.4 mm x 4.8 mm	
Effective Pixels (H x V)	768 x 494	752 x 582
Unit Cell Size (H x V)	8.4 μm x 9.8 μm	8.6 μm x 8.3 μm
Scanning	525 TV lines, 2:1 Interlaced or Non-interlaced	625 TV lines; 2:1 Interlaced or Non-interlaced
Synchronization	HD: 15.734KHz; VD: 59.94.0Hz	HD: 15.625KHz; VD: 50Hz
TV Resolution	H: 570 TV Lines; V: 375 TV Lines	H: 560 TV Lines; V: 450 TV Lines
S/N Ratio	56dB (AGC OFF, Gamma 1.0)	
Min. Illumination	0.03 lux	
Video Output	1 V p-p, 75ohm (BNC or 12 pin Hirose)	
AGC	AGC/MGC selectable	
Gamma	Gamma 0.45/1.0 selectable	
Frame Mode	Frame/Field Mode selectable	
Electronic Shutter	1/60 ~ 1/31,000 selectable	
Lens Mount	C-Mount	
Operating Temperature	-10 °C ~ +55 °C	
Power Requirement	12V DC, 210mA, 2.5W	
Dimension	50mm x 39mm x 83mm	
External Synchronization	Internal/External Auto Switch	
Asynchronous Capture	Standard	
Low Speed Shutter	2 FLD ~ 16 FLD (Optional)	
Long Term Integration	1/30 sec. ~ 2 sec. (user control)	
Weight	155 g	

1.6 Camera Dimension

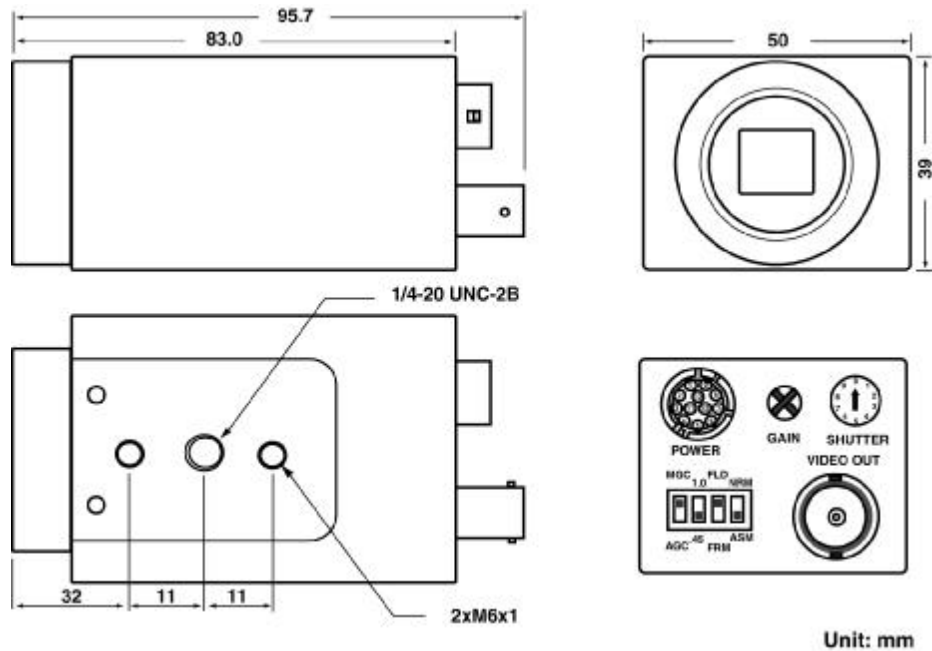

2. Camera Setup

2.1 Basic Camera Setup

For basic camera setup, as shown in Figure 1, one UM-300/UM-301 camera, one standard C-mount lens, one TV monitor, one PS-12C power supply unit or equivalent, and one BNC cable (75Ω) are required. Make sure the camera has the correct settings before powering up. See section 3 for details.

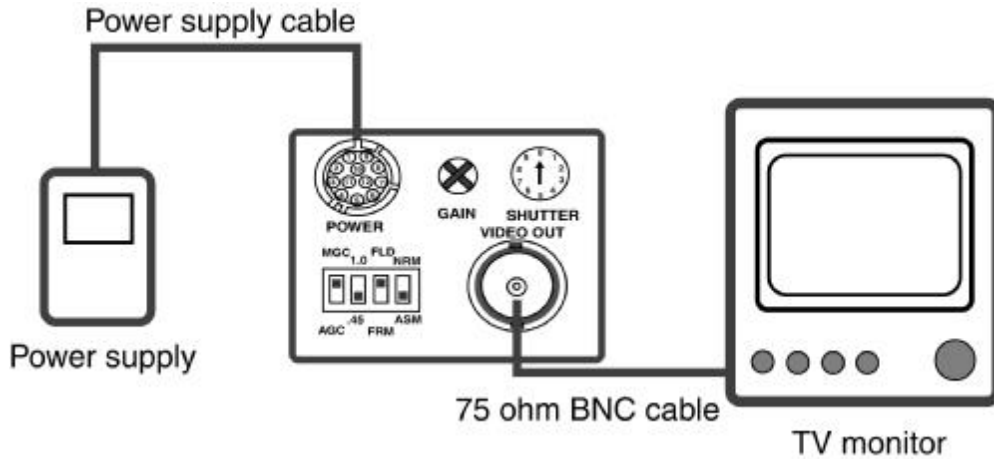

Figure 1. Basic Camera Setup

2.2 Camera and Frame Grabber System Setups

A basic camera and frame grabber system setup, as shown in Figure 2 below, requires a UM-300/UM-301 camera, a standard C-mount lens, a PS-12C power supply, a PC system and VGA monitor, a frame grabber or interface card, and an external trigger device if necessary.

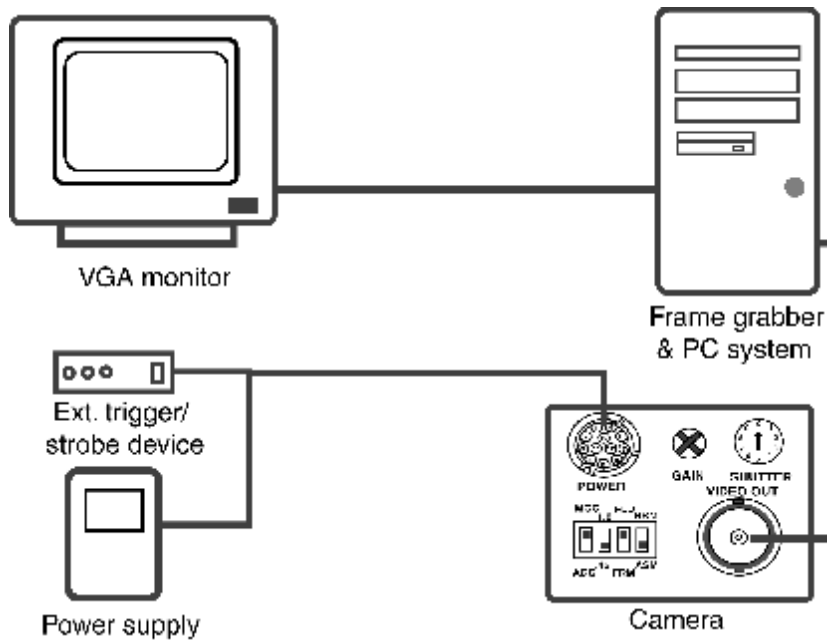

Figure 2. Camera and Frame Grabber System Setup

3. Camera Functions

3.1 12-Pin Connector

The 12-pin Hirose connector is located on the rear plate of the camera. All ground signals on pin # 1, 3, 5, 8, 10, and 12 are common grounds. Although +12 V DC input is recommended on pin #2, this camera should withstand +12 V ± 1V input voltage. Make sure to set the NRM/ASM switch to NRM position on rear plate for external HD and VD locking. Apply TTL signal on HD (pin # 6), VD/VINT (pin # 7) inputs if necessary, see section 4 for details. Figure 3 below shows a top view of the 12-pin Hirose connector.



Figure 3. 12-Pin Hirose Connector

Pin No.	Description	Note
1	GND	
2	+12V DC input	
3	GND	
4	Video	
5	GND	
6	External HD	TTL
7	External VD/VINT	TTL
8	GND	
9	N/C	
10	GND	
11	Integration control	TTL
12	GND	



Figure 4. Shutter Speed Dial Switch

3.2 Shutter Speed Dial Switch

Shutter speed dial switch is located on the rear panel (Figure 4). For normal shutter speed, it has 9 different shutter speeds to select from. Position # 0 is standard scanning speed, 1/60 second. As “Position #” goes higher, the shutter speed goes higher and the video becomes darker. For asynchronous reset shutter speed, an ext. TTL signal is required to trigger the camera. 8 different shutter speeds can be selected. Custom controlled shutter speed can be applied at position #9, see section 4 for details.

Position No.	Shutter Speed (sec.)	Asynchronous Capture (sec.)
0	1/60 (Off)	
1	1/120	1/120
2	1/250	1/600
3	1/500	1/1000
4	1/1000	1/2400
5	1/2000	1/4500
6	1/4500	1/6000
7	1/6000	1/10000
8	1/10000	1/31000
9	1/31000	Pulse Width Control

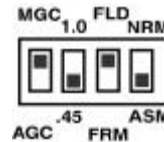

Figure 5. Mode Switch

3.3 Normal and Asynchronous Capture Mode (NRM/ASM)

For normal operation, either with or without shutter speed, NRM should be selected. For asynchronous capture and strobe applications, ASM should be selected. Detailed timing diagrams are shown in section 4.

3.4 Gain Control Mode (AGC/MGC)

Automatic gain control (AGC):

AGC/MGC switch is located on the rear plate.

AGC factory setting is 2V for AGC control and 3V for AGC MAX control. Therefore, the maximum gain is about 18dB as shown in Figure 6 below. AGC setting cannot be changed through the rear gain potentiometer.

Manual gain control (MGC):

The manual gain control can be adjusted from 5dB to 18dB through the gain potentiometer on rear plate.

Note: 32dB gain can be obtained through custom orders.

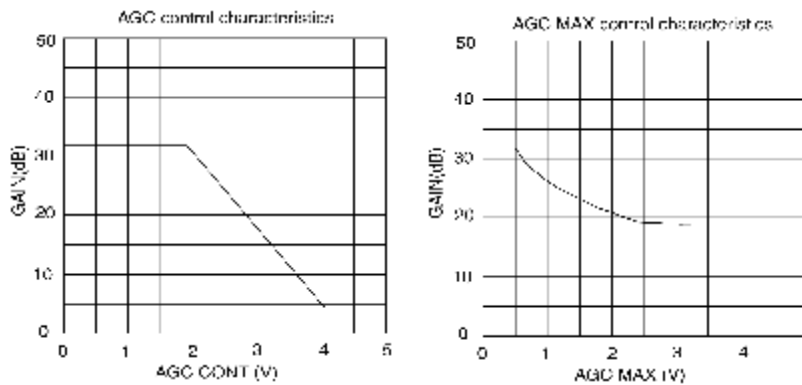

Figure 6. AGC and AGC MAX Control Characteristics

3.5 Gamma 1.0 and 0.45 Mode

Gamma is the numerical value of the degree of contrast in a television picture. Gamma correction is the system response modification by providing linear transfer characteristic from the input to output. In general, circuit built into a TV camera to compensate for non-linearity that exists in display tubes. If the camera is connected directly to a frame grabber, it is desired to set to Gamma 1.0. For direct connection to a TV monitor, gamma 0.45 is recommended, since TV monitor has a non-linear correction. In general, gamma 0.45 is noisier than gamma 1.0, which is why gamma 1.0 is chosen for machine vision applications. Gamma 0.45 is preferred when seeing video at low light level, which is common for inspection by human eyes.

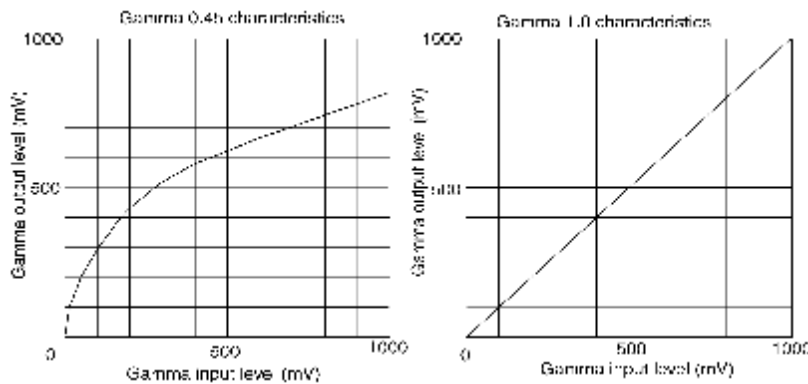

Figure 7. Gamma 1.0 and 0.45 Characteristics

3.6 Field and Frame Mode (FLD/FRM)

Field Mode:

Field/Frame mode switch is located on the rear panel. In field mode, two adjacent horizontal lines are combined and scanned out as shown in figure 8 shown below. There is one line offset between odd field and even field. The sensitivity in field mode is double for each field scanning (1/60 second). For any moving image capture, field mode is recommended in order to avoid the smearing phenomenon. However, the resolution is only one field, not full frame resolution.

Frame Mode:

In frame mode, every other horizontal line is scanned out; this is different from field mode as described above. For odd field, line 1 is scanned out first. For even field, line 2 is scanned first. Each field has 1/30 sec. period. Both odd and even field combined will form a full frame, a period of 1/30 second. For strobe, long-term integration, and non-moving image capturing, frame mode is recommended. In order to obtain a full frame image, a frame grabber must be applied to capture the image. It's difficult to distinguish the difference between field mode and frame mode on a standard TV monitor. In frame mode, shutter function is **disabled**.

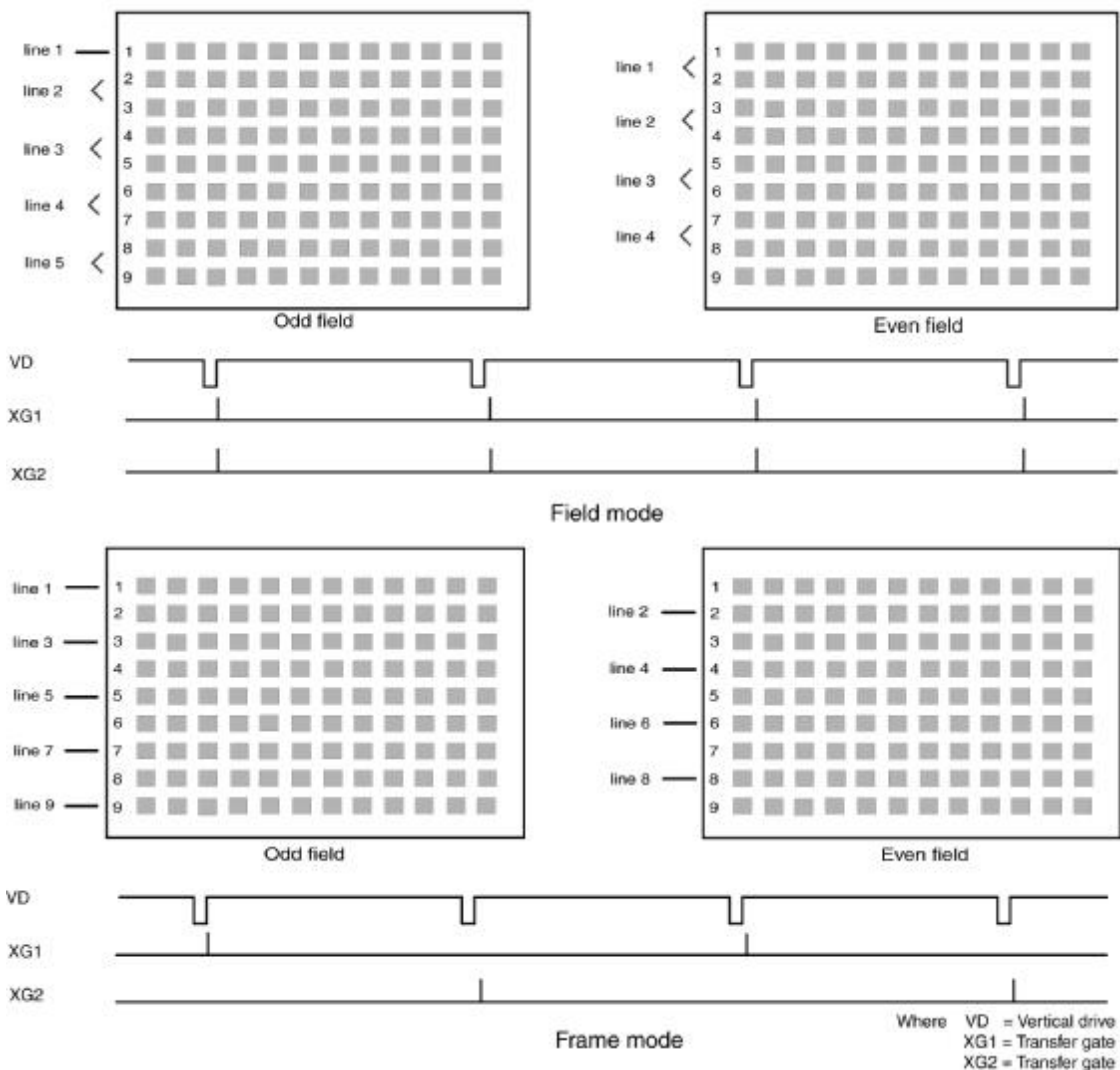

Figure 8. Field and Frame Mode

4. Timing Signals

4.1 Asynchronous Capture Mode (Shutter position from #1 to #8)

Make sure NRM/ASM switch is set to ASM mode and FLD/FRM switch is set to FLD mode.

The camera can be reset by providing an external vertical initialized pulse (VINT), see figure 9 shown below. The VINT pulse width is recommended to be greater than 1H, or 63.5 μ sec. Discharge occurs within 1H of VINT so that external VINT will be latched with HD. There is almost no delay in capturing (delay is only $< 1HD$). XSUB, the vertical substrate pulse, also locks with HD. The exposure or integration period is between the falling edges of XSUB and XFER, the transfer gate pulse. This exposure time should match the shutter speed set on the rear panel of the camera. For example, if the shutter speed on rear panel reads #1 (1/125), then the exposure should be equal to 1/125 sec. Once XFER occurs, the new reset shutter video will appear. The camera only outputs one vertical sync pulse reset; it is much easier for frame grabber to capture asynchronous Video.

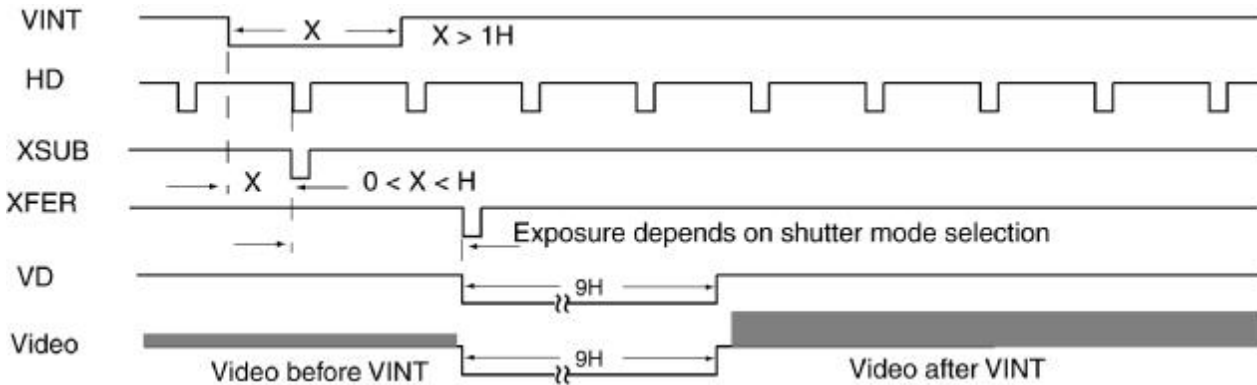

Figure 9. Asynchronous Capture Timing

4.2 Pulse Width Shutter Control (Position #9)

Make sure NRM/ASM switch is set to ASM mode and FLD/FRM switch is set to FLD mode.

This pulse width shutter control is similar the normal asynchronous capture, except the shutter speed or exposure time depends on the VINT pulse width, X. For example, if X = 3H according to figure 10 below, the exposure time in this case is 3H or 0.19msec. The minimum exposure time is 1H or 63.5 μ sec., and the maximum exposure time can be up to a few frames without significant noise.

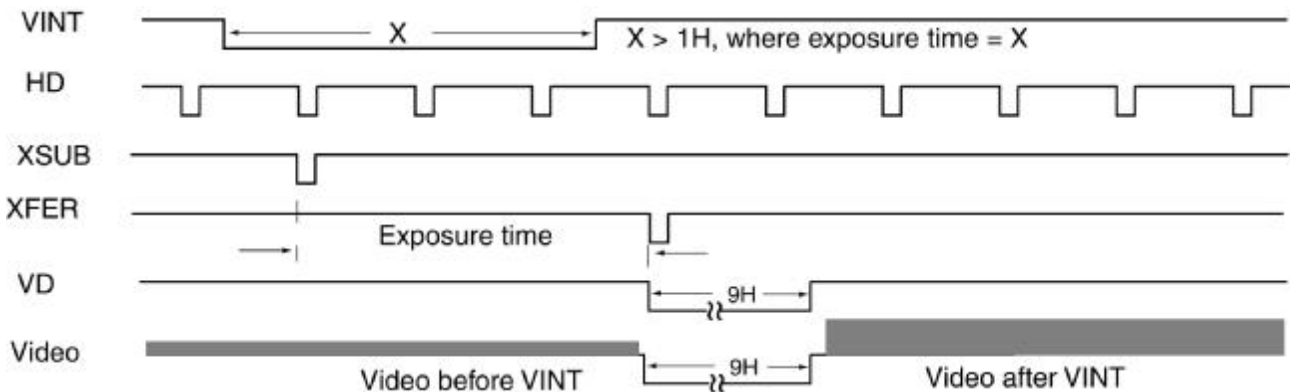
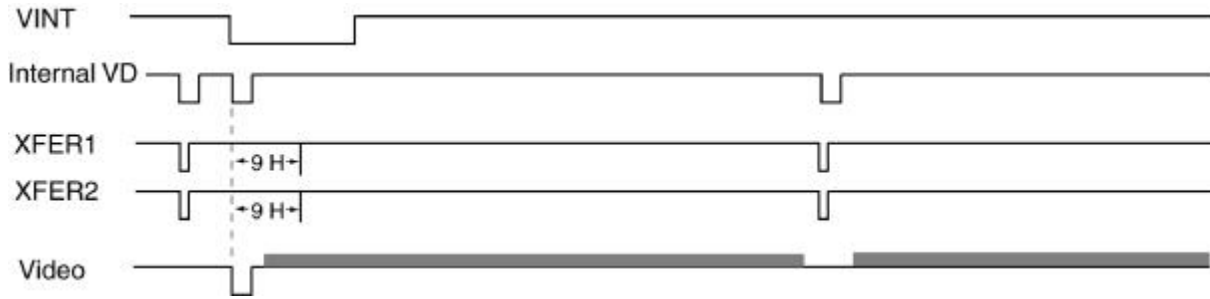

Figure 10. Pulse Width Timing

4.3 Asynchronous Capture in Field Mode (Shutter position at 0)

Set NRM/ASM switch to ASM position and FLD/FRM switch to FLD position.



4.4 Asynchronous Capture in Frame Mode (Shutter position at 0)

Set NRM/ASM switch to ASM position and FLD/FRM switch to FRM mode.

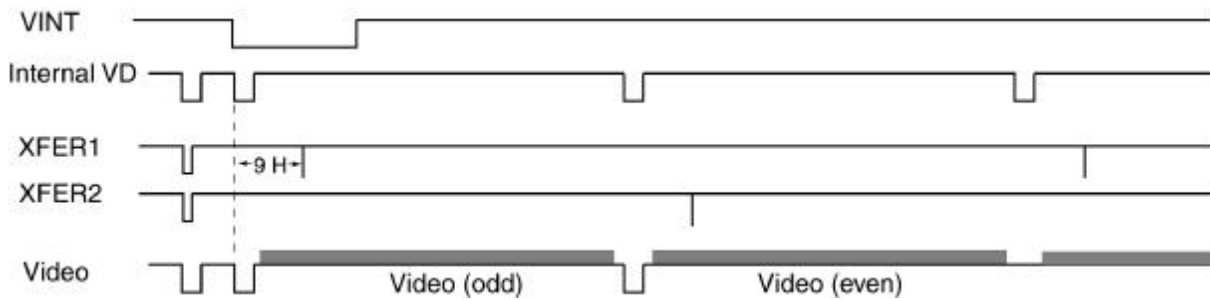

4.5 External Synchronization and Gen-lock

The UM-300/UM-301 camera automatically locks to the external sync source. The external sync source must match the camera HD and VD specification, which are 15.734KHz and 59.94Hz respectively. Both external HD and VD are TTL level signals.

a) HD

- H: 2.5V to 5V
- L: 0V or GND
- Pulse width: 5-50% duty cycle, see figure 10 shown below.

b) VD

- H: 2.5V to 5V
- L: 0V or GND
- Pulse width: 0.5-50% duty cycle; must be RS-170 format (odd and even fields).



Figure 11. External Synchronization and Gen-lock Timing

4.6 Integration

The UM-300/UM-301 camera can be integrated up to 2 seconds without severe noise or dark current effect. Make sure the camera is set to frame mode before preceding any integration; this will ensure that there will be a full frame video (both odd and even field). To start integration, pin #11 of the 12-pin connector must be connected to GND or 0V. The integrated video will be shifted out following the next vertical drive after pin #11 goes back to high or 5V level, as shown in figure 11 below. If a frame grabber does not capture the immediate two fields or integrated video, the normal video (before the integration) will display again on the monitor.

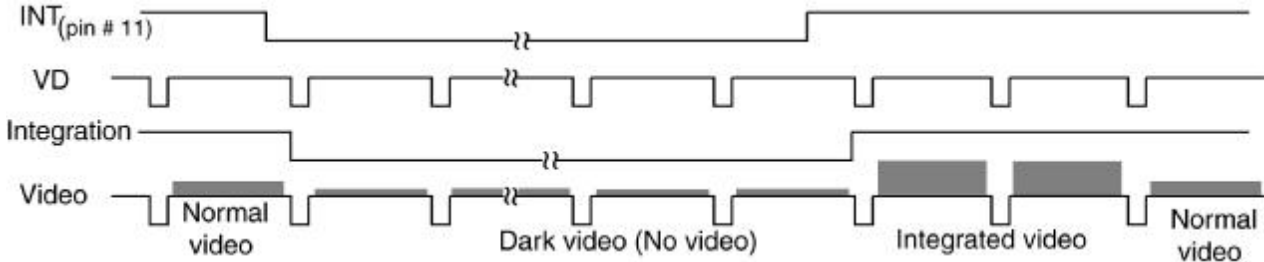

Figure 12. Integration Control Timing

4.7 Strobe

Set NRM/ASM switch to ASM mode and make sure the FRM/FLD switch on rear panel is set to FRM mode in order to achieve full frame resolution. The strobe application is similar to high-speed shutter application except the strobe pulse must occur in the dark and no shutter is required. The advantage to use strobe is that a full frame resolution of video will be obtained. This will not happen when high-speed shutter is applied; a progressive scan or full frame CCD camera must be utilized. The relationship between VINT and strobe pulse signal is shown in figure 13 below. Make sure to fire strobe pulse between 1H and 8H, after the falling edge of VINT. The camera outputs only two vertical sync pulses after reset to signify that the following fields are valid. Therefore, the camera will not have any vertical sync or video if there is no reset pulse.

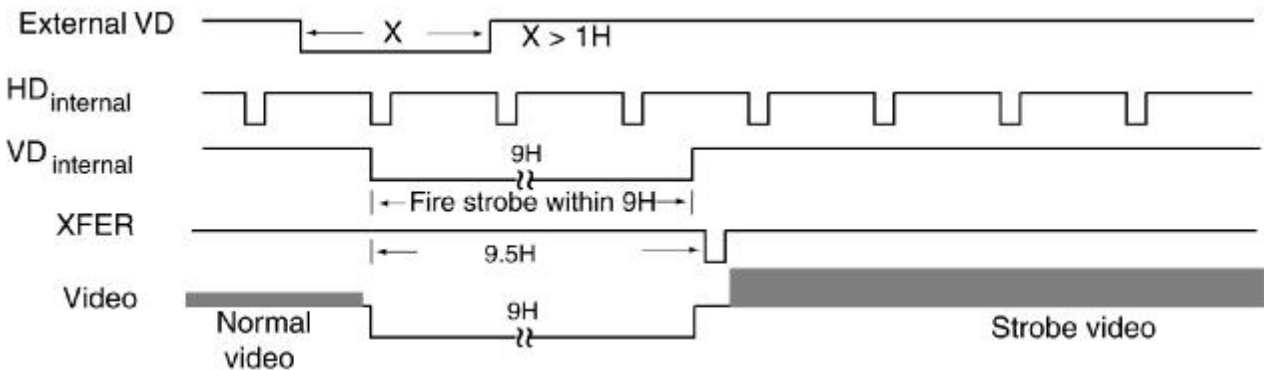

Figure 13. Strobe Timing

5. Camera Malfunction

WARNING: DO NOT ATTEMPT TO OPEN THE CAMERA HOUSING IN ANY CASE WITHOUT CONSENTING THE FACTORY.

Camera malfunction rarely happens. In case camera malfunctions, the following troubleshooting procedures would help to minimize the problem; it definitely helps the user to find out the actual problem and may save a trip for sending the camera back to the factory.

First of all, disconnect the 12-pin Hirose power connector and BNC cable from the camera unit. Make sure there is nothing connected to the camera at this time.

Check the 12V DC power supply at the 12-pin connector cable and make sure it does provide the right voltage to the 12-pin connector.

Make sure to set the camera shutter dial switch back to 0 position and NRM/ASM to NRM location.

If frame grabber was connected to the camera, disconnect it.

Now, power up the camera, and connect it to a TV monitor with a BNC cable. Make sure the monitor and BNC cable are good. Point the camera at a bright scene without a lens on, a blank or bright display should be seen on the TV monitor. Covering the CCD camera with hand or lens cap should see a dark video. If no video occurs, most likely the CCD camera is damaged. Consult the technical support at the factory.

If there is video but it is not clean or bad, it is possible that the CCD imager glass is dirty because of the dirt on CCD glass surface or the CCD camera is partially damaged. Use high-pressure air to blow the dirt away if the CCD glass is not clean. If the problem still exists, contact the UNIQ technical support for help.

If there is video on TV monitor but not with a frame grabber, most likely the problem is from the frame grabber's software or hardware. Consult the frame grabber factory for further details. If a lens is used, make sure the iris is wide open.

6. Technical Support Information

For technical assistance, contact UNIQ Technical Support or Applications Engineer at

Phone: (408) 330-0818

Fax: (408) 330-0886

Email: tech@uniqvision.com

Company contact information:

UNIQ

3220 Scott Blvd.

Santa Clara, CA 95054 USA

Phone: (408) 330-0818

Fax: (408) 330-0886

Our website: www.uniqvision.com

Sales Inquiries: info@uniqvision.com

Technical Support: tech@uniqvision.com